

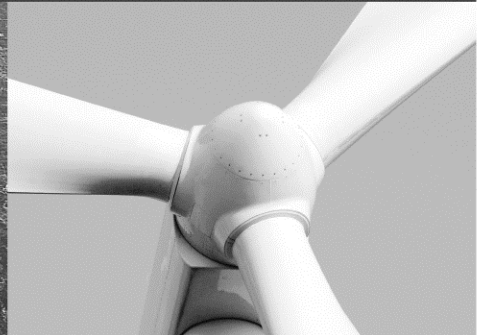

-power in control

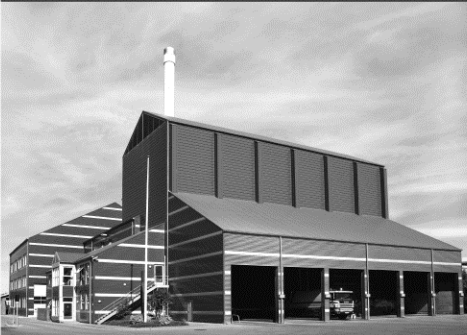

DATA SHEET



Load sharing units, LSU-113DG ANSI code 90

- For control of diesel and gas generators
- Built-in power and frequency transducer
- Reverse power protection/unload and trip
- Constant power or isochronous mode
- LED indication of status/activated control
- 35 mm DIN rail or base mounting



DEIF A/S · Frisenborgvej 33 · DK-7800 Skive
Tel.: +45 9614 9614 · Fax: +45 9614 9615
info@deif.com · www.deif.com

Document no.: 4921240120J

Application

The LSU-113DG is a control unit for control of the prime mover in a power unit.

The LSU-113DG can control the power unit

- in stand-alone mode, performing frequency control
- parallel with grid, performing power control
- parallel with other power units, performing frequency and power control

The unit is designed for connection to a mechanical speed governor, however in conjunction with the DEIF electronic potentiometer type EPN-110DN or EPQ-96 it can control electronic speed governors as well.

The LSU-113DG has a built-in frequency transducer. If a very stable frequency is wanted, an external frequency transducer common for all the LSU-113DGs in the power plant can be connected. If a number of power units are to be synchronised to the busbar at the same time, the frequency may likewise be controlled externally.

Function

The LSU-113DG is measuring the voltage and the current from which the frequency and the power produced by the power unit are measured. The built-in power transducer is based on an $I \times \cos \phi$ principle.

The following couplings are available:

- 1W(4) – single phase
- 1W3 – 1-element 3-phase, 3-wire, balanced load

If unbalanced load can be expected, an external power transducer with an output of 4...20 mA can be connected to the LSU-113DG. In this case the built-in $I \times \cos \phi$ transducer is automatically interrupted.

The power and frequency measured by each LSU-113DG are fed to 2 paralleling lines for comparison with the frequency (FS) and power (PS) of the other connected LSU-113DG.

If L1 or L2 is disconnected from the LSU-113DG at the same time as a power unit in a power plant is disconnected from the power line (busbar), built-in relays in the LSU-113DG ensure that the power output and the frequency output of the associated unit are disconnected from the paralleling lines. Likewise the power and frequency outputs are disconnected if the auxiliary voltage to the LSU-113DG is disconnected.

The LSU-113DG is equipped with an unload input and a "low power" output. When activated the input will control the power unit to zero power, and the output will trip the breaker below $P < 5\%$ of P_{nom} . At the same time the input is activated, the power output of the LSU-113DG is disconnected from the paralleling line.

The LSU-113DG is provided with a reverse power output. The setpoint for this output is:

- P >5% fixed delay 5 s or 10 s
- P >10% fixed delay 5 s or 10 s

The calibration of the LSU-113DG is done so it matches its power unit. This means that load sharing between power units with different size will be performed according to the actual size of the individual power unit in the plant. E.g. a 100 kW PU and a 150 kW PU running in parallel will share a total load of 125 kW into 50 kW and 75 kW. If the 150 kW PU is derated to 100 kW by means of the DERATING potentiometer on the front of the LSU-113DG, the load in the above example will then be shared equally between the 2 power units.

Outputs

The unit is provided with 2 contact outputs for speed control:

Power and frequency control:

The regulating speed of the servomotors for the prime mover is controlled by the built-in P controller of the LSU-113DG according to its setting for:

T_N (min. ON time):

The min. duration of the control pulse when inside the proportional band X_P .

X_P (proportional band):

The zone within which the pulse/pause ratio changes proportionally to the frequency/power deviation from the required value.

T_P (Period time):

The time between the beginnings of two subsequent relay pulses.

Dead band:

The zone within which no control pulses are emitted.

Tripping output:

2 change-over contacts, normally de-energised, for low power and reverse power tripping.

Self-monitoring

The LSU-113DG is equipped with a self-monitoring function. The function supervises the built-in microcontroller and hereby verifies if the programme is running correctly. The green LED marked "POWER" is connected to this function. Constant green light indicates that the supply voltage is accepted and the unit is running correctly. Flashing green light 2-3 Hz indicates that the supply voltage is accepted but the unit is running incorrectly. In this situation the status output terminals 17 and 18 are activated (open).

Terminals/function

Connection type	Connect	
1W3 (standard)	L1 to term. 24	L2 to term. 26
1W (betw. phase/neutral)	L1 (P) to term. 24	Neutral to term. 26

Terminal no.	Description/action
1 and 3 X1/X2	Input for supply voltage.
8, 9 and 10 ("P <5%")	After unloading (short-circuit of terminals 33 and 34 ("Unl")) an opening signal is transmitted to the generator circuit breaker when the power has dropped to 5% or less of P_n .
13, 14 and 15 ("-P >5/10% 5 s/10 s")	Relay output for reverse power protection. The -P > setpoint is set by DEIF to either -P >5% (delay: 5 s or 10 s) or -P >10% (delay: 5 s or 10 s).
17 and 18 Sta	Status output, activated (closed) when the supply voltage is connected and the unit is working correctly.
28 and 29 IL1	Input for the current measurement. Note that S1 on the external current transformer is connected to terminal 28, and S2 is connected to terminal 29.
31 and 32 Ext. P.	Must be short-circuited, if the internal power transducer is used (normal). For applications with unbalanced load it is recommended to use an external power transducer (replacing the built-in one). Connect external power transducer to 31 (+) and 32 (-). The output of the external transducer must be 4...20 mA DC. The output of the connected transducer must limit the output to min. 2 mA and max. 22 mA. DEIF transducer type TAS-331DG is recommended.
33 and 34 ("Unl")	May be connected to a potential-free N/O relay contact. When this contact is activated, the power of the generator is regulated to zero (unloading) and the LSU-113DG is disconnected from the PS power line.
35 ("Ref.")	Reference input. Must be connected to term. 36 ("⊥"), if not used. This input is used to control the power unit running in power control mode (fixed load to grid). A +0.5 V...5 V connected to the input with respect to ⊥ will control the PU in the range 10...100% power. The input activates at 0.55 V and deactivates at 0.45 V. Please notice that when this input is active the LSU-113DG is still connected to the PS and FS lines. In this mode the PS line acts only as an output.
37 ("+5V")	Reference output. This voltage output can be used for local power control mode. If terminal 37 is feeding a voltage divider, and the output from the voltage divider is connected to terminal 35, local power control can be performed.
36 ("⊥")	Common earth terminal for the above reference input/output.
38 (FS) and 39 ("⊥")	Paralleling line for frequency sharing of the connected LSU-113DGs.
40 (PS) and 41 ("⊥")	Paralleling line for power sharing of the connected LSU-113DGs. Normally 5 V at nominal busbar voltage and cos phi = 1. If cos phi 0.8 is stated on the label, 4 V correspond to 100% power.
43 and 44 Relay con- tacts "SG"	Relay contact for increase of the speed.
45 and 46 Relay con- tacts "SG"	Relay contact for decrease of the speed.
NOTE: Relay contacts	Relays (SG) should always be connected via external auxiliary relays when a DC pilot motor is applied. A transient suppressor should always be connected across the relay coil of the external relays.

NOTE:

All terminals marked "⊥" are internally connected.

For correct function of the LSU-113DG any analogue DC input must not exceed 110% of its nominal value. To ensure correct power measurement it is important that the AC current input does not exceed 110% of its nominal value. To accomplish this it is important to take the value of the max. cos phi into consideration when ordering/configuring the LSU-113DG, e.g. by using the kVA figure of the generator and cos phi = 1.

Application

The schematic drawings on the next page show the different couplings for the LSU-113DG. For further information, please see the Application notes for Uni-line, doc. no. 4189340150.

Schematic drawings

Master/Slave Mode

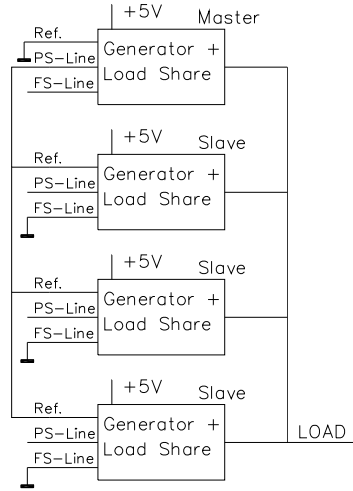

Normal load sharing

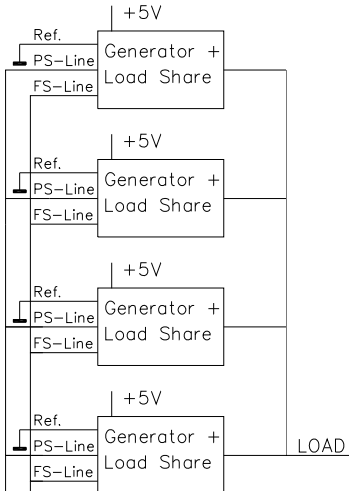

Fixed load to busbar -
No frequency control

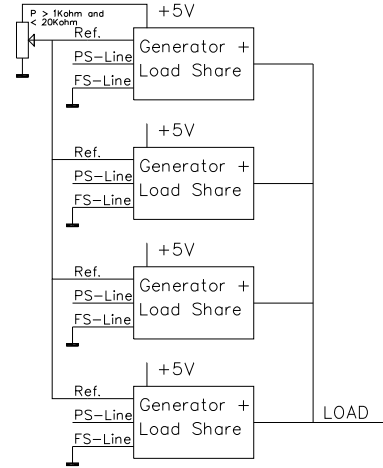

1 generator for fixed load
3 for load sharing

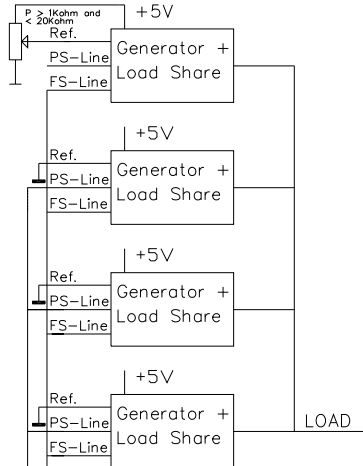

Load sharing with external frequency control
(Synchronising of generator in island operation)

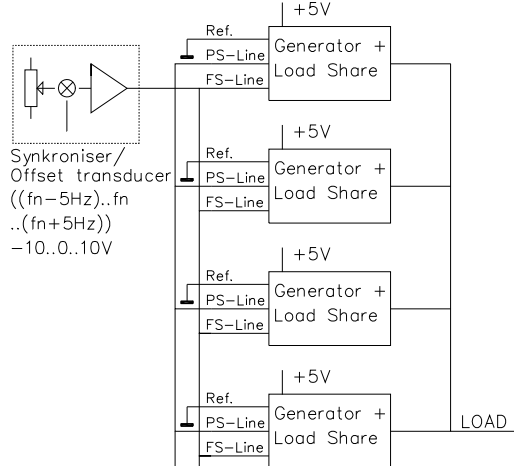

Technical specifications

<p>Meas. current (I_n): 0.3-0.4-0.5-0.6-0.8-1.0-1.3-1.5-2.0-2.5-3.0-4.0-5.0 A AC (calibration modules) UL/cUL listed: 0.4...5.0 A AC</p> <p>Adjusted range: 75...100% of I_n (e.g. 0.45, adjusted by means of a built-in potentiometer) (Lowest meas. range: 0.3 A)</p> <p>Overload: 4 x I_n, continuously 20 x I_n for 10 s (max. 75 A) 80 x I_n for 1 s (max. 300 A)</p> <p>Load: Max. 0.5 VA (per phase) at I_n</p> <p>Meas. voltage (U_n): 57.7-63.5-100-110-127-200-220-230-240-380-400-415-440-450-660-690V AC UL/cUL listed: 57.7...450V AC</p> <p>Voltage range: U_n 60...120%</p> <p>Overload: 1.2 x U_n, continuously 2 x U_n for 10 s</p> <p>Load: 2 kΩ/V</p> <p>Frequency range: 40...45...65...70 Hz</p> <p>Inputs: Unload: Potential-free relay contact Open: 5 V. Closed: 5 mA UL/cUL listed: +/-5V DC (using pot. free ext. contacts)</p> <p>Reference input: 0.5...5 V ±1% (10...100% power) Input resistance: ≥2 MΩ</p> <p>Ext. power input: 4...20 mA DC ±2%</p> <p>Ext. frequency input: -5...0...5 V ±2% ~ 0...±2.5 Hz Max. -10...0...10 V ~ -5...0...5 Hz</p> <p>Contact outputs: Speed control: 2 make contacts P< -P>: 2 change-over contacts</p> <p>Contact ratings: AC1/DC1: 250V AC/24V DC, 8 A AC15/DC13: 250V AC/24V DC, 3 A UL/cUL listed: Resistive load only</p> <p>Life electrical: 1 x 10⁵ (nominal value)</p> <p>Analogue outputs: PS line, FS line: 2 parallel, analogue lines (-5...0...5 V) 5 V ±2% = 2.5 Hz ~ 100% power 0 V ±2% = 0 Hz ~ 0% power</p> <p>Reference output: Reference voltage: 5.0 V ±1% Load: Max. 5 mA (R ≥ 1 kΩ) UL/cUL listed: +/-5V DC</p>	<p>Optocoupler outp.: System status off = Failure Max. voltage 30V DC, max. current 5 mA Voltage drop 1.5 V ~ 2 mA UL/cUL listed: 30V DC, 5 mA</p> <p>Temperature: -25...70°C (-13...158°F) (operating) UL/cUL listed: Max. surrounding air temp. 60°C/140°F</p> <p>Temperature drift: Setpoints: Max. ±0.2% of full scale per 10°C/50°F</p> <p>Galv. separation: Between meas. voltage, meas. current, relay outputs, analogue inputs/outputs and aux. voltage: 3250 V - 50 Hz - 1 min.</p> <p>Supply voltage (U_n): 57.7-63.5-100-110-127-220-230-240-380-400-415-440-450-660-690V AC ±20% (max. 3.5 VA) 24-48-110-220V DC -25/+30% (max. 2.5 W) UL/cUL listed: Only 24V DC and 110V AC DC supply must be from a class 2 power source</p> <p>Climate: HSE, to DIN 40040</p> <p>EMC: To EN 61000-6-1/2/3/4, SS4361503 (PL4) and IEC 255-3</p> <p>Connections: Max. 4.0 mm² (single-stranded) Max. 2.5 mm² (multi-stranded)</p> <p>Materials: All plastic parts are self-extinguishing to UL94 (V1)</p> <p>Protection: Case: IP40. Terminals: IP20, to IEC 529 and EN 60529</p> <p>Type approval: The Uni-line components are approved by the major classification societies. For current approvals see www.deif.com or contact DEIF A/S.</p> <p>UL markings: Wiring: Use 60/75°C (140/167°F) copper conductors only Wire size: AWG 12-16 or equivalent Installation: To be installed in accordance with the NEC (US) or the CEC (Canada)</p>
--	---

Settings

Setting of	Range
T _N Min. ON time	25...500 ms
X _P Proportional band	0...±50% of P _n 0...±2.5 Hz of set frequency
Frequency	45...65 Hz
Derating	50...0% of P _n
Reverse power	-5% of P _n or -10% of P _n , 5 s or 10 s
Low power	5% of P _n
Period time, T _P	10*T _N (5*T _N , 15*T _N and 20*T _N available with jumper settings)
Power deadband	+/- 2% of P _n (or for derated value) (+/- 4% available by jumper setting)
Frequency deadband	+/- 0.1 Hz (+/- 0.25 Hz available by jumper setting)

Please refer to the “Customisation manual” for details about jumper settings.

Indication

LEDs	Lit	Switched off
U _G Generator voltage	(Green) Present	Failure
-P> 5%/10% Reverse power	(Yellow) Fault	Normal Associated re- lay deactivated
P<5% Low power	(Yellow)	
Unload Unloading of this generator	(Green) Gen. unloaded	Normal load
SG▲ Increase speed (power)	(Yellow) Relay activated	Relay not activated
SG▼ Decrease speed (power)		

Once the unit has been mounted and adjusted, the transparent front cover may be sealed to prevent unwanted change of the setting.

Connections/dimensions (in mm)

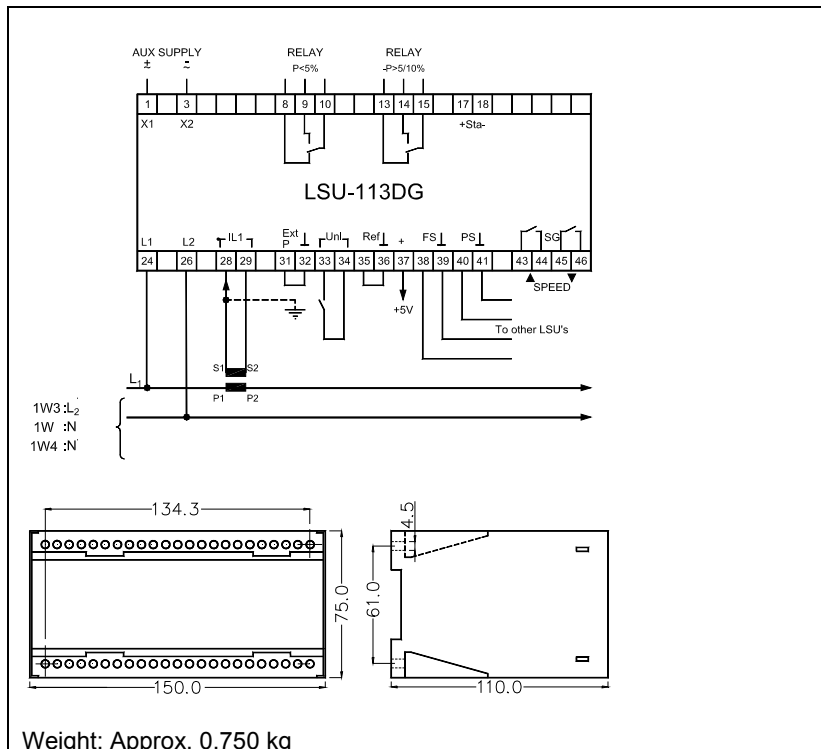

Available variants

Item no.	Variant no.	Variant description
2913060160	01	LSU-113DG - DC supply
2913060160	02	LSU-113DG - AC supply

Order specifications

Variants:

Mandatory information										Additional options to the standard variant
Item no.	Type	Variant no.	Coupling	Measuring power (P _n)	Setpoint "P>"	Delay	Cos Phi	Meas. voltage	Supply voltage	Option

Example:

Mandatory information										Additional options to the standard variant
Item no.	Type	Variant no.	Coupling	Measuring power (P _n)	Setpoint "P>"	Delay	Cos Phi	Meas. voltage	Supply voltage	Option
2913060160-01	LSU-113DG	01	1W3	100 W	5%	10 s	0.8	100 V	24V DC	No options available

Note: Measuring power = $\frac{\text{Primary power}}{\text{CT ratio} \times \text{VT ratio}}$

Due to our continuous development we reserve the right to supply equipment which may vary from the described.



DEIF A/S, Frisenborgvej 33
DK-7800 Skive, Denmark

Tel.: +45 9614 9614, Fax: +45 9614 9615
E-mail: deif@deif.com, URL: www.deif.com

